



UNITRON **ASTRONOMICAL TELESCOPES**

UNITRON Instruments, Inc.
Subsidiary of Ehrenreich Photo-Optical Industries, Inc.

101 Crossways Park West
Woodbury, NY 11797 U.S.A.
Telephone (516) 364-8046

general information on **UNITRON** refractors

OBJECTIVES

The proud owner of a new UNITRON refractor is impatient for the stars to appear so that he can test his telescope. But did you know that other types of optical instruments are also given a "star test" to evaluate their performance? For example, a microscope objective is focused on an "artificial star" created by a pinhole in a silvered glass slide. If the lens is capable of forming a perfect image of a tiny point of light, it will certainly perform well with the larger objects for which the optics were designed.

This example will help to explain why the requirements for a first-class *astronomical* objective are so severe. Because of the nature of the objects observed, the astronomer is "testing" his telescope each time he uses it. However, no such exacting performance is expected of a telescope designed for observing land objects; for this reason, such instruments often fail miserably when trained on the stars. Keeping in mind the critical importance of the objective lens, you will understand why refractors which appear similar when you look at them, perform so differently when you look *through* them.

UNITRON's achromatic objectives are designed to meet the most exacting requirements of the professional astronomer. Exclusive lens formulae, use of the newest types of optical glass, painstaking care in manufacture — these are some of the ingredients of a UNITRON objective. Full correction is made for spherical and chromatic aberration and for coma. Lenses are not cemented but *air-spaced* to permit superior corrections, prevent strain under extremes of temperature, and insure freedom from clouding with age. The objective is anti-reflection coated to provide highest image contrast and maximum light transmission. Skilled observers, who use their UNITRONS for research, regularly report double-star observations which exceed the Dawes criterion for resolving power.

To insure accurate and permanent alignment, the lens blanks are mounted in a precision machined "inner" metal cell which uses a push-pull screw mechanism to introduce the correct amount

of pressure without distortion. This inner cell, in turn, screws into an "outer cell" installed on the tube. "Squaring-on" to the optical axis is done with extreme care to allow the full capabilities of the objective to be realized. In the 3-inch and larger UNITRONS, the outer cell includes an adjustment mechanism to provide for the highest degree of accuracy in collimation.

From start to finish, a UNITRON objective is processed with an almost fanatical insistence on perfection. This is why a UNITRON easily outperforms other refractors of equal size and telescopes of other types with much larger apertures.

SPECIFICATIONS

	2.4"	3"	4"	5"	6"
Diameter (mm)	62	78	105	130	160
Aperture (mm)	60	75	100	125	155
Focal Length (mm)	900	1200	1500	2000	2500
Focal Ratio	f/15	f/16	f/15	f/16	f/16
Resolving Power	1.9"	1.5"	1.1"	0.89"	0.74"

EYEPIECES

UNITRON eyepieces have been especially designed to provide the best optical match both to the UNITRON objective and to the retina of the eye on which the image is ultimately formed. Fitted lens cells, accurate centration, and coated optics are but a few of the special features which contribute to optimum performance.

The observer uses low-powered eyepieces for their wide field of view, medium powers for general observing, and high powers for the study of fine detail. To insure best results through the entire range of magnification, the optical design for each of the UNITRON eyepieces has been selected with reference to its focal length. The designs used are Kellner (K), Monochro (M), Ramsden (R), Achromatised Symmetrical (A.S.) and Orthoscopic (O).

Eyepieces available in the following focal lengths:
K-60mm, M-40mm, R-25mm, K-18mm,
K-12.5mm, A.S.-9mm, A.S.-7mm,
O-6mm, O-5mm, and O-4mm.

The eyepieces may be used directly in the telescope drawtube or in such accessories as the UNIHEX Rotary Eyepiece Selector, Star Diagonal, DUETRON Double Eyepiece Holder, or Erecting Prism System. In any model, the magnification of the eyepiece is determined by dividing its focal length into the focal length of the objective.

Though an international standard exists for the diameter of eyepieces used in microscopes, there is no such standard for telescope eyepieces. The diameters of UNITRON eyepieces have been chosen on the basis of utility and optimum design. Most eyepieces have outside diameter 24.5mm, while those of 40mm and 60mm focal length have diameters 1¼" and 58mm respectively. Remember it is the optical design of the eyepiece and not the outside diameter of the metal barrel which determines the field of view.

ACHROMATIC AMPLIFIER

UNITRON's Achromatic Amplifier — a standard-equipment accessory with all models — is a two-element, Barlow-type, negative amplifying lens designed especially for the optical system of UNITRON Refractors. When used with the Standard UNIHEX or Star Diagonal, the customary power of each eyepiece is doubled. The high powers obtainable with the Amplifier are ideal for planetary and lunar observations and for separating close, multiple stars.

The magnification factor of 2X has been selected as the most useful for general observing under a wide variety of atmospheric conditions. Experienced observers know that the maximum power which can be used to advantage depends on the aperture of the telescope, the quality of the "seeing," and the individual vision of the observer. Indiscriminate use of high powers results in magnification which is "empty"; the amount of detail which you can see is actually reduced. We emphasize this point for beginners who are often confused by misleading advertisements which rate telescopes by their "power", or offer high powers which are completely worthless for the instrument in question.

2.4 inch ALTAZIMUTH REFRACTOR

by **UNITRON**



UNIHEX

ACHROMATIC AMPLIFIER
for the UNIHEX.

MODEL 114 — Complete with Altazimuth Mounting and slow motion controls for both altitude and azimuth, tripod and leg brace with eyepiece shelf, 5X-16mm viewfinder, Standard rack and pinion focusing mechanism, choice of UNIHEX or star diagonal plus erecting prism system, 4 coated eyepieces, Achromatic Amplifier, sun-glass, dewcap, dustcap, wooden cabinet, instructions.

FOUR EYEPIECES INCLUDED* —

9mm (100X), 12.5mm (72X), 18mm (50X), 25mm (35X)

ADDITIONAL EYEPIECES AVAILABLE* —

4mm for 225 power	6mm for 150 power
5mm for 180 power	7mm for 129 power
40mm for 22 power†	

ADDITIONAL ACCESSORIES AVAILABLE —

UNIHEX Rotary Eyepiece Selector‡
DUETRON Double Eyepiece Holder
Astro-Camera 220 with Accessories
Sun Projecting Screen with UNICLAMPS
Sun Diagonal (Herschel Solar Wedge)
Solar Aperture Diaphragm
Erecting Prism System‡
2.4" UNICLAMP Camera Bracket
2.4" Counterbalance Clamp

* Powers indicated are doubled when the Achromatic Amplifier is used.

† Must be used in UNIHEX or in special adapter.

‡ Available as standard equipment as noted.

Observing with UNIHEX: The old-fashioned method of fumbling with eyepieces in the dark has been outmoded by the UNIHEX Rotary Eyepiece Selector which puts 6 magnifications at your fingertips. To change power, merely rotate a new eyepiece into position while the object stays centered in the field of view. Assume you are observing a region of the Orion Nebula. You may start with the lowest powers to look at the nebulosity and then gradually increase the magnification to study the Trapezium and the finer nebular details. The convenience and speed with which such a sequence of observations can be made adds much to the pleasure of observing. The ACHROMATIC AMPLIFIER for UNIHEX is mounted in a special cell to fit this accessory.

"I would like to compliment you on the highly superior optics, mounting, and general performance of the model 114. I found the UNIHEX rotary eyepiece holder especially handy. Through city smog and glare M27 was a beautiful dumbbell-shaped mist, M57 (the ring nebula) showed some annularity, the quadruple star Epsilon Lyrae was no great challenge, the companion of Polaris was an easy object even at 36X, and even though only about ten degrees above the horizon, the rings of Saturn showed some detail."

D.D. Yonkers, N.Y.

general information on **UNITRON** refractors

(continued)

EQUATORIAL MOUNTINGS

UNITRON's Equatorial mountings are of massive design. Oversized components insure the stability so necessary for serious work and effortless observing. The mounting can be easily and accurately set to the latitude of your observing station, using a fine adjustment collar. An azimuth clamp provides for the North-South orientation.

Slow-motion controls as well as rapid-motion clamps are provided for both declination and right ascension. Celestial objects can thus be rapidly centered and kept in the field of view. A flexible cable control allows comfortable adjustment of the right ascension hand drive, even when a clock drive is not used. Of course, a UNITRON clock drive may be added for automatic tracking.

All Equatorial Models have setting circles to help locate celestial objects too faint to be seen easily in the viewfinder. The hour circle is divided into units of 10 min. and the declination circle into units of 2 degrees. In the 3" and larger Equatorial Models, a vernier is included for readings to 1 minute in hour angle and to 5 minutes in declination.

The base of the Equatorial mounting is cylindrical to fit into the head of the wooden field tripod or the fixed metal pier.

ALTAZIMUTH MOUNTINGS

UNITRON Altazimuth mountings are exclusively designed with slow motion as well as rapid motion controls for both altitude and azimuth. Flexible cable extension controls are standard on the 4" Model and are available for other altazimuth models at extra cost. Contrast the unique construction, as shown in the illustrations, with the usual altazimuth mountings, which are often little more than a universal joint with no satisfactory means of controlling the movement of the telescope tube. UNITRON mountings are noted for their sturdiness, portability, and ease of operation.

TELESCOPE TUBES

Duralumin body tubes of exceptional rigidity at minimum weight are designed to balance perfectly on the mountings. Tube interiors are painted flat black, and anti-glare diaphragms prevent internal reflections and increase image contrast. A threaded cell at the front of the tube holds the objective lens frame. A large dew-cap prevents dew formation on the lens surface and keeps out stray light. UNITRON tubes are handsomely finished in white enamel.

TRIPODS AND METAL PIERS

A sturdy wooden tripod is included with each of the portable models. Metal spikes at the tips of the legs make firm contact with the ground. For the smaller models, a tripod leg brace is supplied to prevent accidental spreading of the legs. For the 3" Equatorial and larger UNITRONS, a handy tripod shelf replaces the brace and, in addition, provides convenient storage space for accessories. Braces and shelves have holes drilled for the convenient storage of eyepieces. The 4" and larger models are also available with metal pier for permanent installation since many owners of the pier models have small observatories for their UNITRONS.

CLOCK DRIVES

The earth "stands still" for you or your Astro-Camera when you use a UNITRON Clock Drive to follow celestial motions. All UNITRON Equatorial Models are available with the Synchronous Motor Drive. The 4" — 160 series and larger models can, in addition, use UNITRON's weight-driven Clock Drive which features adjustable speed control and requires no electrical power.

All equatorial models have a second, supplementary R.A. slow motion to facilitate changes in this coordinate without the need to stop or disengage the clock. This feature is included on all UNITRON instruments, even those ordered without the drive, in case you should choose to add this accessory at a later date.

FOCUSING MECHANISMS

UNITRON diagonal-cut, micrometric, rack and pinion mechanisms allow rapid and accurate focus of the image. UNITRON 2.4" and 3" Refractors use the **Standard** focusing mechanism. The friction sleeve holds either the 36.2mm diameter drawtube with eyepiece holder or, alternately, the tubes of accessories such as UNIHEX, DUETRON, the Astro-Camera 220, etc. The **Deluxe** mechanism of the 3" Photo-Equatorial (Model 145) and the 4" Altazimuth (Model 150) is of more sophisticated design, with locking clamps for both the sleeve and drawtube to prevent motion during photography. The 4" and larger equatorial models use the **Super** rack and pinion with its 58mm diameter drawtube to accommodate the giant, wide-field 60mm eyepiece and the Super-UNIHEX. In photographic models, the Super mechanism has a graduated scale to facilitate focus of the camera.

ACCESSORIES

Each UNITRON comes complete with an assortment of useful and valuable accessories as standard equipment. These, plus the viewfinder, eyepieces and Achromatic Amplifier, make your telescope complete and ready to use. As you read the descriptions of each model, note how many accessories of unique and patented design are included with your UNITRON — accessories available with other brands only at extra cost. The precision quality of UNITRON accessories explains their widespread sale to professional observatories, to industrial firms for use in special apparatus, and to amateur astronomers who wish to modernize their present equipment.

FITTED CABINETS

UNITRON telescopes arrive in handsomely-finished wooden cabinets which offer complete protection on field trips as well as safe storage when instruments are not in use.

2.4 inch EQUATORIAL REFRACTOR

by **UNITRON**



MODEL 128 — Complete with Equatorial Mounting and slow motion controls for declination and R.A., extension flexible-cable R.A. control, supplementary R.A. slow motion and provision for attaching accessory motor drive, setting circles, tripod and leg brace with eyepiece shelf, 6X-23.5mm viewfinder, Standard rack and pinion focusing mechanism, choice of UNIHEX or star diagonal plus erecting prism system, 5 coated eyepieces, Achromatic Amplifier, sun projecting screen, sunglass, dewcap, dustcap, wooden cabinets, instructions.

MODEL 128C — same as Model 128 but with Synchronous Motor Clock Drive mechanism, in addition.

FIVE EYEPIECES INCLUDED* — 7mm (129X),
9mm (100X), 12.5mm (72X), 18mm (50X), 25mm (35X)

ADDITIONAL EYEPIECES AVAILABLE* —

4mm for 225 power	6mm for 150 power
5mm for 180 power	40mm for 22 power†

ADDITIONAL ACCESSORIES AVAILABLE —

UNIHEX Rotary Eyepiece Selector‡
DUETRON Double Eyepiece Holder
Astro-Camera 220 with Accessories
Sun Diagonal (Herschel Solar Wedge)
Solar Aperture Diaphragm
Erecting Prism System‡
2.4" UNICLAMP Camera Bracket
2.4" Counterbalance Clamp

* Powers are doubled when the Achromatic Amplifier is used.

† Must be used in UNIHEX or in special adapter.

‡ Available as standard equipment as noted.

Observing with DUETRON: With the Double Eyepiece Holder, two observers may use the telescope simultaneously. A focusing sleeve is provided so that the eyepieces used need not be of the same magnification. DEUTRON is ideal for father and son teams and for those who buy their UNITRON in partnership. With DUETRON, more observers may be accommodated at star parties and the advanced members may provide valuable instruction to the beginners.

Tracking with the SYNCHRONOUS MOTOR DRIVE: After you have located a celestial object, the Synchronous Motor Clock Drive will keep it centered in the field of view, allowing you to devote your full attention to observing. The compact size in no way interferes with the portability of the telescope. The precision mechanism operates silently, without vibration, and with the accuracy of an observatory clock.

"Quite a while ago I purchased a 2.4" refractor. This instrument exceeded my greatest expectations. It gives a perfect image every time I use it . . . Nebula and clusters are seen without trouble. I have seen over 20 Messier objects and all were excellent. Double stars are no problem . . . Epsilon Lyrae shows as a quadruple at 100X. Albero is quite a sight at 35X in Cygnus . . . your telescopes seem to be the finest and best priced instruments on the market."

S.M. Brooklyn, N.Y.

to help you choose a telescope refractors and reflectors

The UNITRON telescopes described in these pages are refractors. A large lens, the objective, is mounted in front of the tube and gathers the rays of light. At the eye end of the telescope, a primary image is formed which is magnified by an eyepiece. Reflecting telescopes use a parabolic (or sometimes spherical) mirror placed at the bottom of a tube to collect the light and bring it to a focus. In the Newtonian reflector a plane mirror or prism is placed inside the telescope tube at an angle of 45° with the axis of the mirror and directs the rays to the outside of the tube where they may be magnified with an eyepiece. With a refractor, the observer looks into the eyepiece along the line of sight to the celestial object or else into a right angle attachment at the eyepiece end; with the Newtonian reflector, the observer always looks into the side of the tube at the top. With a large reflector of this type, observing positions tend to become awkward as the observer bends over the tube while standing on a ladder. Unless the tube can be rotated in the mounting some observing positions become physically impossible. Both refractors and reflectors have special points in their favor for particular applications and both types are used to advantage in professional observatories.

For the average amateur, whether beginner or advanced observer, a UNITRON refractor has many advantages which recommend it as the logical choice. In a refractor there are no optical elements to adjust nor is there any need for servicing. On the other hand, the mirrors of reflectors become oxidized and require periodic restoration with a frequency depending on local atmospheric conditions. This nuisance of reconditioning is further aggravated by the subsequent need to realign the mirrors, a time-consuming procedure which is also called for any time the instrument has been subjected to vibration.

Temperature effects are particularly troublesome for the reflector. They produce unsteady images, poor definition and set an upper limit to the usable magnifica-

tion. These difficulties stem in part from differences in air temperature within the open-ended tube which produce currents of air with different indexes of refraction. Through this turbulent air, the light must pass twice as it is folded back on itself on its way to the eyepiece. Observing conditions which tend to reduce this turbulence are precisely those which will aid internal dewing of the optical surfaces with consequent loss of light and definition. The refractor with its closed tube is subject to none of these difficulties. Another troublesome temperature effect is due to unequal cooling of different parts of the thick mirror as it is used during an evening's observation. Until thermal equilibrium has been attained in the mirror itself and between the mirror and surrounding air, the figure of the reflecting surface is changed so that definition is impaired. In the refractor, the thinner lenses of the achromatic objective cool rapidly and the effects of unequal contraction tend to cancel each other in the compound lens with the result that the refractor is always ready for instant use.

The superior definition of the refractor is also due to the absence of the secondary mirrors and supports which are characteristic of all types of reflecting telescopes. These obstructions produce diffraction effects which modify the image and are hence damaging to definition. These disadvantages inherent in the reflector make it significantly inferior to the refractor for the observation of planetary and lunar images, fields which are of particular interest to the amateur. Furthermore the f/15 focal ratio of the refractor provides larger planetary and lunar images at the prime focus so that the higher magnifications are obtained with eyepieces of longer focal length. The amateur also appreciates the wider field of view of the refractor and, in a UNITRON Refractor, the sharp definition to the very edge of the field.

Inexpensive reflectors are tempting to the beginner who sees in them an opportunity to get a "big" telescope for a small investment. Poor optical performance

combined with the usual unstable mounting can do no more than hint at what there is to be seen with a good instrument. Such a telescope is frustrating to use and usually discarded before long as a barrier to progress. Similar remarks apply to instruments of any type which use "surplus" optics designed for terrestrial observation in part of the optical system which require lenses corrected for observing point sources at infinity.

In the more expensive cassegrain type of reflector the overall size of the telescope is reduced by combining a short focal length parabolic mirror with a small secondary hyperbolic mirror. However, it is difficult to construct these mirrors to the required degree of accuracy and in the classical cassegrain design all of the problems associated with the open-tube construction still remain. More recently, several catadioptric cassegrain designs have been introduced which combine mirrors and lenses. In all cases, however, the multiplicity of optical elements aggravates the problem of maintaining optical alignment and the original factory collimation can easily be lost during normal handling. It is equally clear that each additional optical element reduces light transmission and, of even more importance, reduces image contrast. When compared with images seen through a UNITRON refractor, the sharp crisp contrast between the object viewed and the background is noticeably lacking.

In summary, if it seems that the refractor has undergone little change throughout the years, this fact is a tribute to its basic soundness of design. However, in UNITRON Refractors the objective has been carried to the peak of perfection by the use of types of optical glass and computer lens calculation techniques not available in earlier days. Superior image quality and trouble-free performance explain why UNITRON continues to be America's most popular telescope, the telescope which has withstood the test of time.

"... when the sun set, my 4" UNITRON was all ready, no lining up, or fussing around with diagonals or mirrors, or all the other discomforts with the reflectors. There I had reflectors from 16" down to compare with my 4" refractor, and the results were amazing. My UNITRON compared favorably with reflectors with over twice the aperture, in fact even 12" reflectors didn't disclose any more than my 4" UNITRON. You have done a wonderful job supplying the amateur with a usable instrument."

R.W.D. Parsippany, N.J.

"I have written you many times in the past about the success which I have had over the past few years in planetary observing with the 4". About a year ago I purchased a 6" Reflector . . . Last year I used both telescopes on Saturn in a simultaneous observation program . . . the 4" Reflector showed Saturn plainer and more distinct than did the 6" . . . I have compared my planetary drawings to those drawings of other observers using even 8" and 10" Reflectors and they show nothing more than can be detected with my Model 150."

R.G. Pen Argyl, Pa

"I was pleased with the prompt service I received in delivery of my UNITRON Model 160V. As you have heard so many times, I find it to be excellent in all respects, even beyond your advertised claims. I was able to photographically confirm the observation of asteroid Iris, an accomplishment I would never even have attempted with my 8" reflector. I have had it out nearly every clear night since I received it."

W.G. San Antonio, Texas

3 inch ALTAZIMUTH REFRACTOR

by **UNITRON**

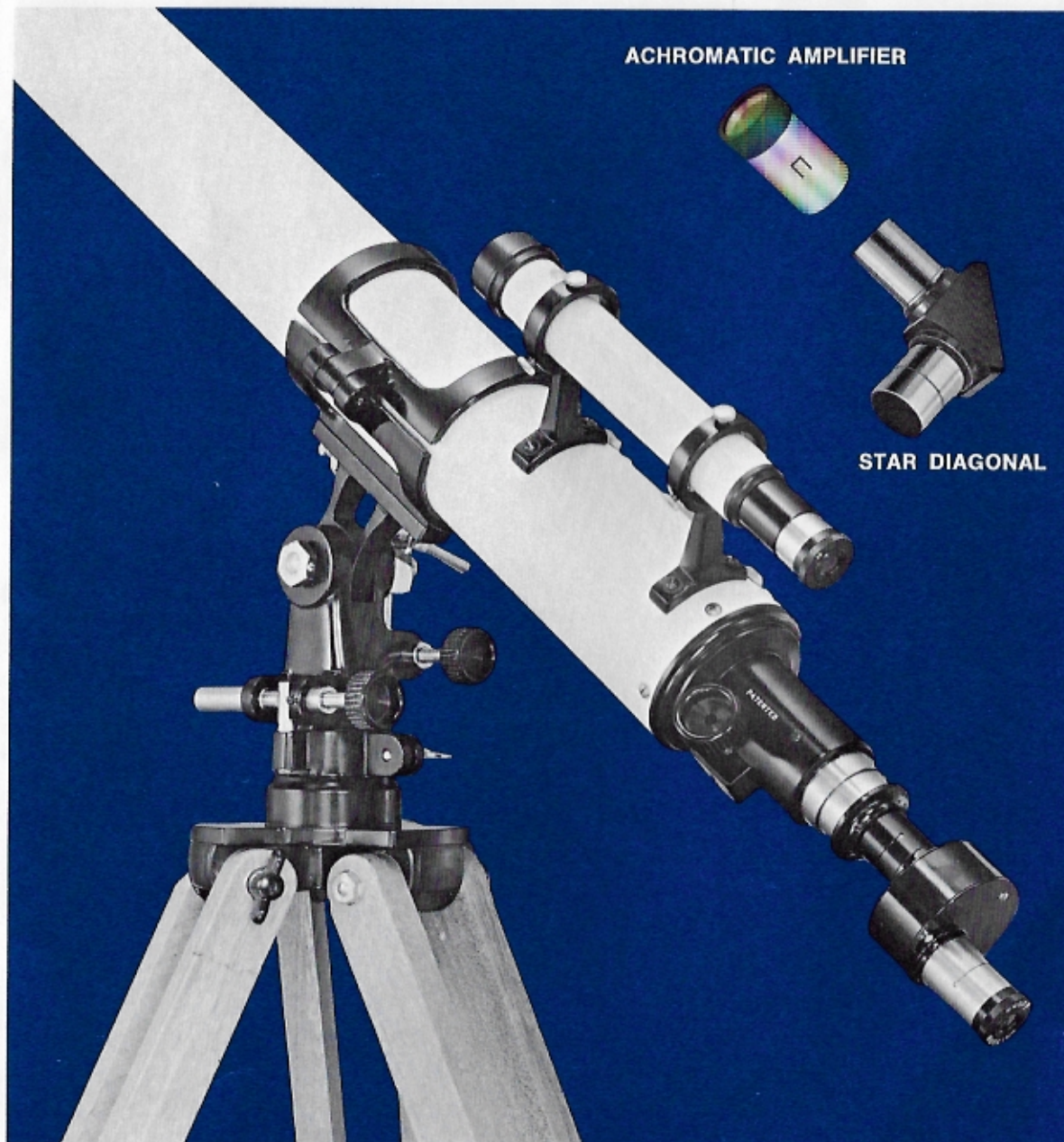

ACHROMATIC AMPLIFIER

STAR DIAGONAL

MODEL 140 — Complete with Altazimuth Mounting and slow motion controls for both altitude and azimuth, tripod and leg brace with eyepiece shelf, 8X-30mm viewfinder, Standard rack and pinion focusing mechanism§, choice of UNIHEX or star diagonal plus erecting prism system, 5 coated eyepieces, Achromatic Amplifier, sunglass, dewcap, dustcap, wooden cabinet, instructions.

FIVE EYEPIECES INCLUDED* — 7mm (171X),
9mm (133X), 12.5mm (96X), 18mm (67X), 25mm (48X)

ADDITIONAL EYEPIECES AVAILABLE* —
4mm for 300 power 6mm for 200 power
5mm for 240 power 40mm for 30 power†

ADDITIONAL ACCESSORIES AVAILABLE* —

UNIHEX Rotary Eyepiece Selector‡
DUETRON Double Eyepiece Holder
Astro-Camera 220 with Accessories
Sun Projecting Screen Apparatus
Sun Diagonal (Herschel Solar Wedge)
Solar Aperture Diaphragm
Erecting Prism System‡
3" UNICLAMP Camera Bracket
3" Counterbalance Clamp

* Powers indicated are doubled when the Achromatic Amplifier is used.

† Must be used in UNIHEX or in special adapter.

‡ Available as standard equipment as noted.

§ The **Deluxe** rack and pinion is available at additional cost.

Observing with the **ERECTING PRISM SYSTEM**: An astronomical telescope gives an inverted image. The UNITRON Erecting Prism System contains a Porro prism system to re-invert the image for land observation. It may be used with any of the eyepieces to give the same complete range of terrestrial magnifications as for celestial observation. The thrilling, closeup views of distant objects far surpass in clarity and brilliance those obtained with a telescope designed for land viewing alone.

Observing with the **STAR DIAGONAL**: With the prismatic star diagonal the observer may view at right angles to the telescope tube — a useful observing aid when the celestial object is nearly overhead. The diagonal may also be rotated so that observations may be made comfortably while sitting as well as standing. The **ACHROMATIC AMPLIFIER** for the star diagonal is mounted in a special cell to fit this accessory.

"The optics of my 3" model 140 are unexcelled by any telescope anywhere as far as I'm concerned. Here are the results I obtained: night of Aug. 24 I resolved Zeta Hercules, components of 3.0 and 6.5 magnitudes and a separation of 1.3" of arc. I not only resolved the stars but observed clear dark sky between the two components . . . Then on the early morning of August 25 I resolved the star Eta Orionis into its separate components of 3.8 and 4.8 magnitudes and 1.4" of arc separation. It resolved beautifully under magnifications of 131X and 171X as had Zeta Hercules the night before."

R.C. Artesia, N. Mex.

to help you choose a telescope

mountings and sizes

THE TELESCOPE MOUNTING

As important as the telescope itself, is the mounting which supports it and guides its motion. A flimsy, unstable mounting is worthless in an astronomical telescope, since the slightest vibration of the tube is magnified to produce a wildly dancing image. With such a mounting, the lightest breeze, a mere adjustment of the focusing knob, or a change of the tube position will render the telescope useless until the image becomes quiet.

Due to the earth's rotation, any astronomical object will slowly drift from the field of view of a stationary telescope and some means must be provided for moving the tube to follow the object. To point a telescope in any direction it must be movable about two axes and these are most conveniently set at right angles to each other. In the **altazimuth** mounting, the tube is movable in altitude (up and down) and in azimuth (right and left). The limitation of the altazimuth mounting lies in the fact that two adjustments are required to follow the star as it moves out of the field of view. In the UNITRON altazimuth mountings slow motion controls are provided to facilitate this adjustment but even here it must be made on the basis of trial and error. Consequently, the observer must devote part of his time and effort to keeping the telescope trained on the object instead of spending it more profitably in observing.

In an **equatorial mounting**, one of the axes is inclined parallel to the axis of the earth and points exactly toward the celestial pole. This axis is called the **polar**

axis, while the other at right angles to it is called the **declination axis**. The UNITRON Equatorials have slow motion controls for micrometric rotation about both of these axes. With this mounting, one can compensate for the earth's motion by a rotation about the polar axis alone. In practice, an object once in the field of view may be kept there by merely turning a single control — the right ascension slow motion. If an object is "lost" through interruption of observation, it may easily be re-located. The declination slow motion is used only to aid in centering objects in the field of view when they are initially located. With a clock drive, usable only with the equatorial type of mounting, the tracking is done automatically, leaving the observer completely free to concentrate on observing. The equatorial is the only type which can be used for taking photographs which require an exposure of long duration.

To mount a telescope equatorially raises problems of stability and design which are solved satisfactorily only by means of a mounting of greater mechanical complexity than is required for an altazimuth telescope. Consequently, the equatorial is the more expensive of the two types. With either type, slow motion controls are essential to permit the tube to be moved smoothly and accurately. Cheap telescopes are sometimes provided with a universal-joint type of mounting which is often described as a "combination" equatorial and altazimuth. While this description is true from the standpoint of definition, it is quite misleading in that the lack

of stability and slow motion controls is sufficient to disqualify the mounting for astronomical work, whatever the name applied to it.

WHAT SIZE TELESCOPE DOES AN AMATEUR NEED?

Beginners in astronomy are sometimes confused as to the best sized telescope for the amateur or the smallest size which will be suitable for useful observations. Statements in books offer a wide variety of opinions which reflect the personal prejudices of their authors. One article refers to a statement from a professional that the only telescope he has for his personal use is a 1.5" refractor and that a good 3" refractor will show everything that an amateur would want to see. The very same article recommends the 2.4" sized refractor. It quotes the owner of a 10" reflector who, while observing with the 2.4", remarked that he could see as much as with his large instrument, the only difference being that the images were a tiny bit smaller. The author of a well known book on the planets refers to the 3" refractor as the beginners' favorite instrument while stating that no reflector under 6" is of much real use.

The fact is that the owner of a UNITRON of any size will find plenty of worthwhile observations to occupy his attention. There are, however, definite advantages to the larger models. A larger lens, because of its greater surface area, has greater light gathering power than a smaller one. For example, a 3" objective gathers 156% more light than a 2.4" lens. More light means a more brilliant image, and therefore a larger telescope will bring out fainter details and objects. A larger lens also has higher resolving power so that it will separate or "split" double stars into their individual components which would appear as a single star when viewed through a smaller telescope. Similarly, planetary and lunar details appear sharper when viewed through a large telescope than with a smaller one used at the same magnification.

It is rather natural that some should think that a beginner would find a larger telescope more difficult to operate than a smaller one. This is definitely not the case and, if anything, it is actually easier for the novice to locate and observe celestial objects using the larger instrument. The basic principles and operating technique are essentially the same for all models. The extra features of the larger telescopes offer an incentive to the beginner to increase the pleasure of observing by adding to his knowledge of astronomical principles.

Much of the precision and workmanship, built into your UNITRON, is hidden from external view; however, it reveals its presence through the contribution it makes to superb performance. For example, shown here are some of the concealed components in the equatorial mounting of the UNITRON 4" Models 160 and 166: the tapered roller bearings of the polar axis and the radial and thrust ball bearings of the driving worm.

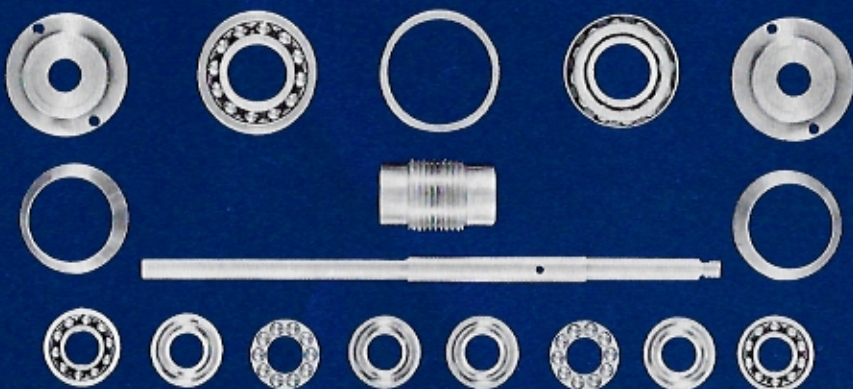

3 inch EQUATORIAL REFRACTOR

by **UNITRON**



MODEL 142 — Complete with Equatorial Mounting and slow motion controls, for both declination and R.A., extension flexible-cable R.A. control, supplementary R.A. slow motion and provision for attaching accessory motor drive, setting circles and veniers, tripod accessories shelf, 8X-30mm viewfinder, Standard rack and pinion focusing mechanisms, choice of UNIHEX or star diagonal plus erecting prism system, 5 coated eyepieces, Achromatic Amplifier, sun projecting screen, sunglass, dewcap, dustcap, wooden cabinets, instructions.

MODEL 142C — Same as Model 142 but with Synchronous Motor Clock Drive, in addition.

FIVE EYEPIECES INCLUDED* — 6mm (200X),
9mm (133X), 12.5mm (96X), 18mm (67X), 25mm (48X)

ADDITIONAL EYEPIECES AVAILABLE* —

4mm for 300 power	7mm for 171 power
5mm for 240 power	40mm for 30 power†

ADDITIONAL ACCESSORIES AVAILABLE —

- UNIHEX Rotary Eyepiece Selector‡
- DUETRON Double Eyepiece Holder
- Astro-Camera 220 with Accessories
- Erecting Prism System‡
- Sun Diagonal (Herschel Solar Wedge)
- Solar Aperture Diaphragm
- 3" UNICLAMP Camera Bracket
- 3" UNIBALANCE Tube Assembly
- Guide Telescope with 3" UNICLAMPS
- Extra Counterweight for Guide Telescope

* Powers indicated are doubled when the Achromatic Amplifier is used.

† Must be used in UNIHEX or in special adapter.

‡ Available as standard equipment as noted.

§ The Deluxe rack and pinion is available at additional cost.

Observing with the SUN-PROJECTING SCREEN: With the sun-projecting screen apparatus, an enlarged image of the solar disk is projected on the white screen where it may be seen by several observers at the same time. Charts may be placed directly on the screen and the position of sunspots plotted.

"I find that my UNITRON 3" Refractor has a perfect optical system, with a first class objective lens and sharp definition. All parts are made with exacting workmanship. I have already obtained excellent views of the Ring Nebula in Lyra, the Hercules cluster, double stars such as 90 Herculis (1.7 sec.), Pi Quilac (1.4 sec.), etc. Tests on these doubles verify your claims as to the resolving power. I have seen planets as remote as Neptune (which is very conspicuous with this refractor) and many details on the surfaces of Saturn, Jupiter, and Mars. The views of all these celestial bodies are a wonder and I am delighted with my UNITRON 3" Equatorial."

Dr. O.S. Caracas, Venezuela

3 inch PHOTO-EQUATORIAL REFRACTOR by **UNITRON**



ASTRO-CAMERA

MODEL 145 — Complete with Equatorial Mounting and slow motion controls for both declination and R.A., extension flexible-cable R.A. control, supplementary R.A. slow motion and provision for attaching accessory clock drive, setting circles and verniers, tripod, tripod accessories shelf, 78X-62mm photographic guide telescope with UNICLAMP mounting brackets and star diagonal, 10X-42mm viewfinder, Deluxe rack and pinion focusing mechanism, UNIHEX Rotary Eyepiece Selector or star diagonal plus erecting prism system, 6 coated eyepieces, Achromatic Amplifier, sun projecting screen, sunglass, UNIBALANCE assembly, dewcap, dustcap, wooden cabinets, instructions.

MODEL 145C (as illustrated) — same as Model 145 but with Synchronous Motor Clock Drive, in addition.

SIX EYEPIECES INCLUDED* —

6mm (200X), 7mm (171X), 9mm (133X), 12.5mm (96X), 18mm (67X), 25mm (48X)

ADDITIONAL EYEPIECES AVAILABLE* —

4mm for 300 power, 5mm for 240 power, 40mm for 30 power.

ADDITIONAL ACCESSORIES AVAILABLE —

UNIHEX Rotary Eyepiece Selector†
DUETRON Double Eyepiece Holder
Sun Diagonal (Herschel Solar Wedge)
Solar Aperture Diaphragm
Erecting Prism System†

* Powers indicated are doubled when the Achromatic Amplifier is used.

† Available as standard equipment as noted.

"I feel obligated to write you about some of the results I am obtaining with my UNITRON 3" Photo-Equatorial. I have observed Uranus at its conjunction with Jupiter, and also Mars and Saturn with great satisfaction. I am equally pleased with my views of the Sagittarius clusters, the Andromeda Nebula, and the Moon. To my astonishment I have seen at 171X a view of Venus that was almost identical to those I have had through an 11½-inch refractor on open nights at the observatory. One feature I should like to mention is the relative light weight of the instrument, which is a boon for people like me who have to carry the instrument to the observing site."

A.L., Jr., Baton Rouge, La.

ASTRO-PHOTOGRAPHY with a UNITRON

Photographic recording of your observations through your telescope will add a new dimension to your observing program. The Astro-Camera 220 can be used on any Altazimuth model to photograph the sun, sunspots, the moon, solar and lunar eclipses, as well as distant terrestrial objects. For stars, nebulae, clusters and comets, an equatorial mounting is necessary. The UNITRON Guide Telescope permits accurate tracking, and for long exposures a clock or motor drive is essential. For star fields a camera of short focal ratio is useful and may be attached to the tube by using a UNICLAMP Camera Bracket. The UNIBALANCE Tube Assembly is used to balance accessories about the declination axis. All of these accessories and features are shown on the model illustrated.

ACCESSORIES for PHOTOGRAPHY —

Astro-Camera 220 with Accessories
3" UNICLAMP Camera Bracket
Synchronous Motor Clock Drive

4 inch ALTAZIMUTH REFRACTOR

by **UNITRON**



MODEL 150 — Complete with Altazimuth Mounting and slow motion controls for both altitude and azimuth, tripod, tripod accessories shelf, 10X-42mm viewfinder, Deluxe rack and pinion focusing mechanism§, choice of UNIHEX or star diagonal plus erecting prism system, Achromatic Amplifier, 6 coated eyepieces, sun-glass, solar aperture diaphragm, dewcap, dustcap, wooden cabinets, instructions.

SIX EYEPIECES INCLUDED*

6mm (250X), 7mm (214X), 9mm (167X),
12.5mm (120X), 18mm (83X), 25mm (60X)

ADDITIONAL EYEPIECES AVAILABLE* —

4mm for 375 power
5mm for 300 power
40mm for 38 power

ADDITIONAL ACCESSORIES AVAILABLE —

UNIHEX Rotary Eyepiece Selector†
DUETRON Double Eyepiece Holder
4" Sun Projecting Screen
Sun Diagonal (Herschel Solar Wedge)
Astro-Camera 220 with Accessories
Erecting Prism System†
4" UNICLAMP Camera Bracket

* Powers indicated are doubled when the Achromatic Amplifier is used.

† Available as standard equipment as noted.

§ Available with the Super rack and pinion at additional cost.

Observing with the SUNGLASS: The sun-glass contains a dark filter made of special heat-resistant glass. It fits over any of the eyepieces for direct observation of the sun. The more sophisticated SUN DIAGONAL (Herschel Solar Wedge) is illustrated in the accessories section.

A SOLAR APERTURE DIAPHRAGM (shown on the tripod shelf) serves to reduce the aperture to prevent overheating. The diaphragm is standard equipment with all 4" and larger models and available for other models as well.

"The UNITRON 4" Refractor functions beautifully. The definition is excellent and the resolving power exceeds your claims. I turned the telescope on Theta Aurigae, a test for a 4", and had no difficulty in resolving the two stars, although the brighter one outshines its close (2.8 second) companion by nearly five magnitudes. Early one morning I tested the scope on Eta Orionis (1.4 second) and had no difficulty. The Trapezium was breathtaking. I have also studied many nebulae and clusters and have had good results in every case."

F.J.H. Long Island, N.Y.

4 inch EQUATORIAL REFRACTOR

by **UNITRON**



MODEL 152 — Complete with Equatorial Mounting and slow motion controls for both declination and R.A., extension flexible-cable R.A. control, supplementary R.A. slow motion and provision for attaching accessory clock drive, setting circles and verniers, tripod with levels, tripod accessories shelf, battery-operated shelf illuminator, 10X-42mm viewfinder, Super rack and pinion focusing mechanism, standard UNIHEx† or star diagonal plus erecting prism system, Achromatic Amplifier, 7 coated eyepieces, sun projecting screen, sun-glass, solar aperture diaphragm, dewcap, dustcap, wooden cabinets, instructions.

MODEL 152C — same as Model 152 but with Synchronous Motor Clock Drive, in addition.

MODEL 155 — **PHOTOGRAPHIC MODEL:** same specifications as Model 152 but with, in addition: 78X-62mm photographic guide telescope with UNICLAMP mounting brackets and star diagonal, UNIBALANCE assembly.

MODEL 155C — same as Model 155 but with Synchronous Motor Clock Drive, in addition.

SEVEN EYEPIECES INCLUDED* — 6mm (250X)
7mm (214X), 9mm (167X), 12.5mm (120X),
18mm (83X), 25mm (60X), 40mm (38X)

ADDITIONAL EYEPIECES AVAILABLE* —
4mm for 375 power
5mm for 300 power
60mm for 25 power

ADDITIONAL ACCESSORIES AVAILABLE —
UNIHEx Rotary Eyepiece Selector†
DUETRON Double Eyepiece Holder
Astro-Camera 220 with Accessories
Sun Diagonal (Herschel Solar Wedge)
Erecting Prism System†
UNIBALANCE Assembly for 152, 152C
4" UNICLAMP Camera Bracket

* Powers indicated are doubled when the Achromatic Amplifier is used.

† Models 152 and 155 are available with the Super-UNIHEx as shown on the 5" Model, in place of the standard UNIHEx, at additional cost.

‡ Available as standard equipment as noted.

Observing with the 60mm EYEPIECE: The wide angle 60mm eyepiece is designed for use with the Super rack and pinion focusing mechanism supplied with the 4" and larger models. It gives spectacular wide field views of the heavens.

"I have your UNITRON 4 inch equatorial and 3 inch altazimuth and both have served me wonderfully. Jupiter shows a great wealth of intricate detail. The Orion Nebula (M42) and the trapezium in it are wonderful and beautiful objects in both low and high power. I consider these two telescopes a work of art — magnificent!"

A. A. H. Concord, N.H.

4 inch PHOTO-EQUATORIAL REFRACTOR with clock drive and astro-camera by **UNITRON**

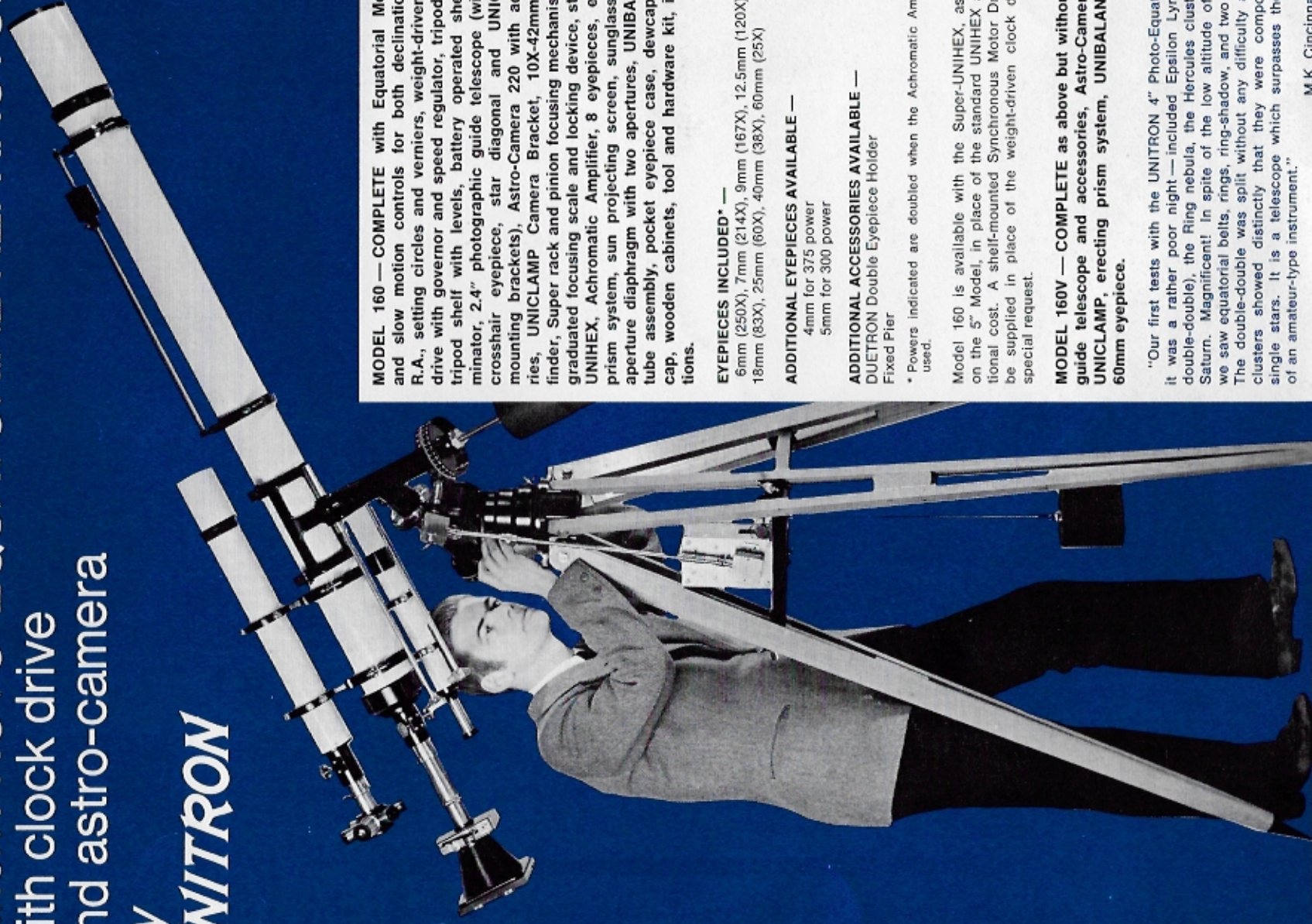

MODEL 160 — COMPLETE with Equatorial Mounting and slow motion controls for both declination and R.A., setting circles and verniers, weight-driven clock drive with governor and speed regulator, tripod, metal tripod shelf with levels, battery operated shelf illuminator, 2.4" photographic guide telescope (with 78X crosshair eyepiece, star diagonal and UNICLAMP mounting brackets), Astro-Camera 220 with accessories, UNICLAMP Camera Bracket, 10X-42mm viewfinder, Super rack and pinion focusing mechanism with graduated focusing scale and locking device, standard UNIHEX, Achromatic Amplifier, 8 eyepieces, erecting prism system, sun projecting screen, sunglass, solar aperture diaphragm with two apertures, UNIBALANCE tube assembly, pocket eyepiece case, dewcap, dustcap, wooden cabinets, tool and hardware kit, instructions.

EYEPIECES INCLUDED* —

6mm (250X), 7mm (214X), 9mm (167X), 12.5mm (120X), 18mm (83X), 25mm (60X), 40mm (38X), 60mm (25X)

ADDITIONAL EYEPIECES AVAILABLE —

4mm for 375 power
5mm for 300 power

ADDITIONAL ACCESSORIES AVAILABLE —

DUETRON Double Eyepiece Holder
Fixed Pier

* Powers indicated are doubled when the Achromatic Amplifier is used.

Model 160 is available with the Super-UNIHEX, as shown on the 5" Model, in place of the standard UNIHEX at additional cost. A shelf-mounted Synchronous Motor Drive can be supplied in place of the weight-driven clock drive on special request.

MODEL 160V — COMPLETE as above but without: 2.4" guide telescope and accessories, Astro-Camera 220, UNICLAMP, erecting prism system, UNIBALANCE, or 60mm eyepiece.

"Our first tests with the UNITRON 4" Photo-Equatorial — it was a rather poor night — included Epsilon Lyrae (the double-double), the Ring nebula, the Hercules cluster, and Saturn. Magnificent! In spite of the low altitude of Saturn we saw equatorial belts, rings, ring-shadow, and two moons. The double-double was split without any difficulty and the clusters showed distinctly that they were composed of single stars. It is a telescope which surpasses the limits of an amateur-type instrument."

M.K. Cincinnati, Ohio

4 inch PHOTO-EQUATORIAL
with fixed pier
clock drive
and astro-camera
by
UNITRON

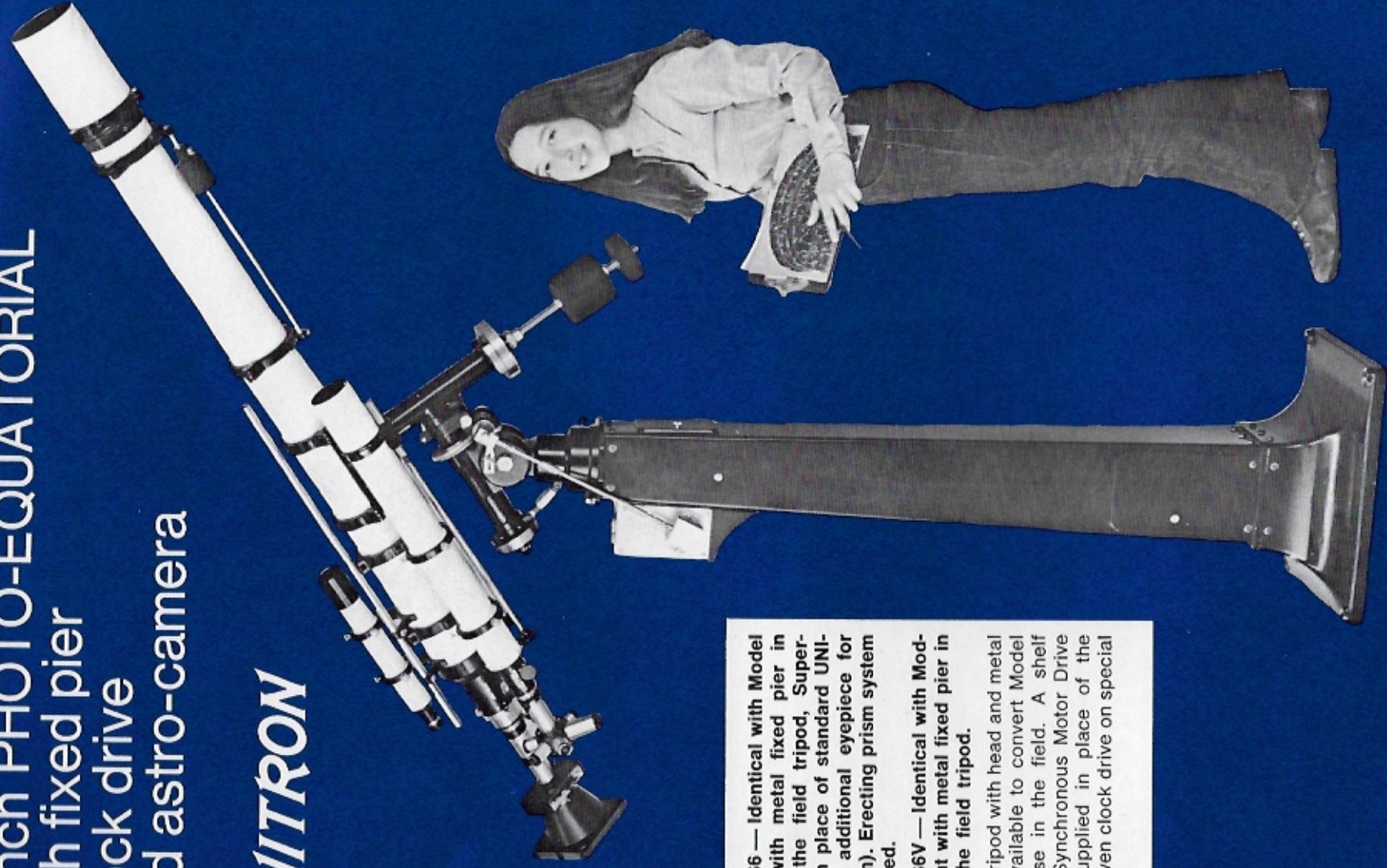

MODEL 166 — Identical with Model 160 but with metal fixed pier in place of the field tripod, Super-UNIHEX in place of standard UNIHEX, and additional eyepiece for 375X (4mm). Erecting prism system not included.

MODEL 166V — Identical with Model 160 but with metal fixed pier in place of the field tripod.

The field tripod with head and metal shelf is available to convert Model 166 for use in the field. A shelf mounted Synchronous Motor Drive can be supplied in place of the weight-driven clock drive on special request.

5 inch
EQUATORIAL
REFRACTOR
with fixed pier
and clock drive
by
UNITRON

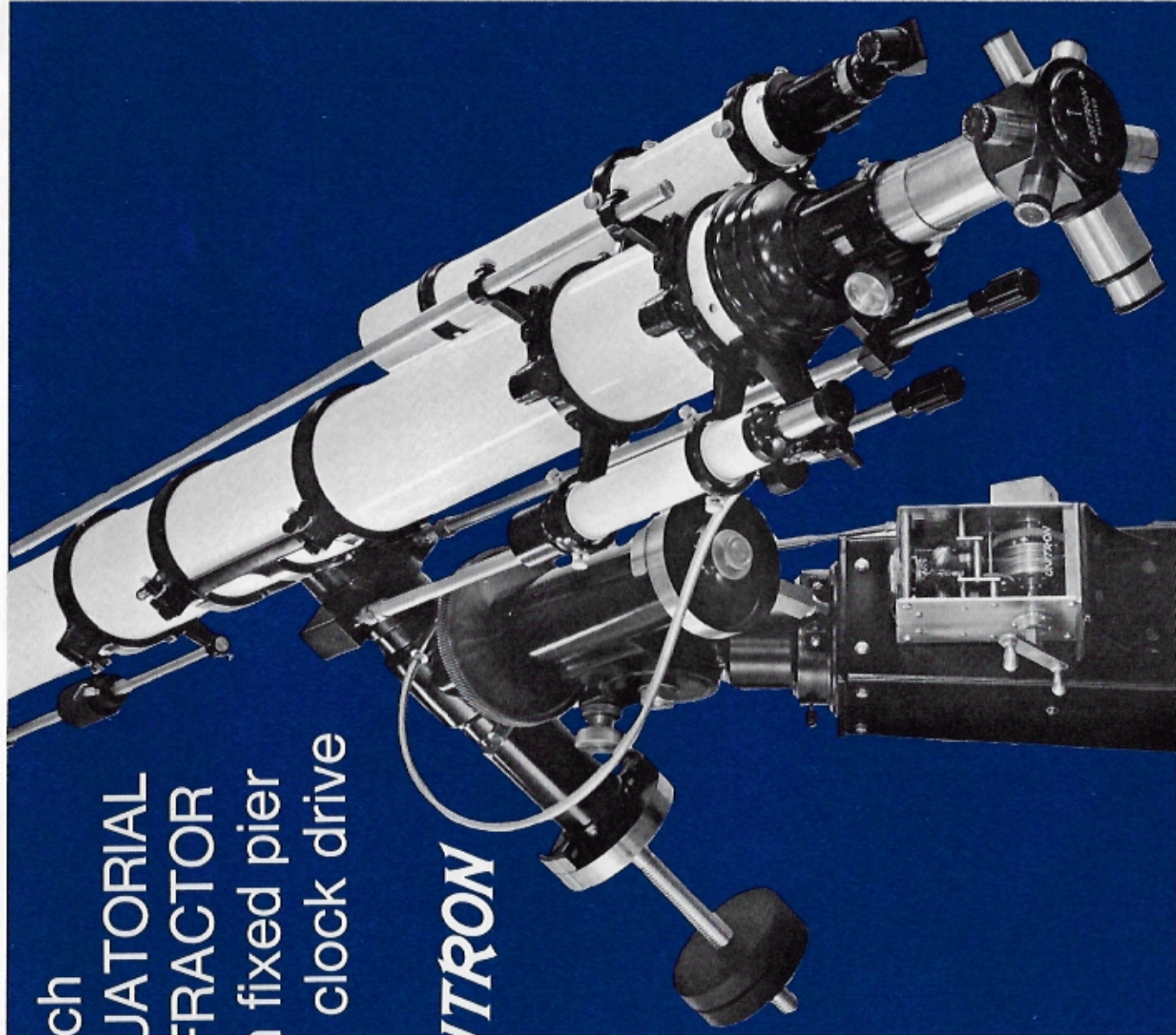

**PICTURE YOURSELF AT THE CONTROLS
OF THIS 5-INCH UNITRON**

Fortunate indeed is the observer who has this UNITRON 5-inch Photo-Equatorial at his command! Owning this mighty UNITRON is not an impossible dream — the price is less than you would expect for an instrument of this size and quality, and purchase may be made using our Easy Payment Plan. Lack of a permanent observatory need be no drawback because a tripod model is also offered; with casters attached to the tripod legs, the complete instrument can be rolled conveniently into any ground-level shelter. Complete specifications on this fine instrument and its wealth of accessories are given in Bulletin 500 available on request.

Observing with Super-UNIHEX:

This rotary eyepiece selector accommodates the giant (58mm o.d.) 60mm eyepiece as well as the 40mm (1 1/4" o.d.) eyepiece; and any four of the standard (24.5mm o.d.) UNITRON eyepieces. Super-UNIHEX may be used only in the Super-Rack and Pinion mechanism as supplied with the UNITRON 4", 5" or 6" Equatorial models.

Tracking with the Weight-Driven Clock Drive:

A special feature of this drive is its complete independence of a source of electric power. Clock speed is maintained at a constant rate by means of a spinning governor rotating within ball bearing supports. A speed regulating control is readily accessible on top of the housing. Complete protection of the precision gears is provided by a chromed brass and plexiglass outer case.

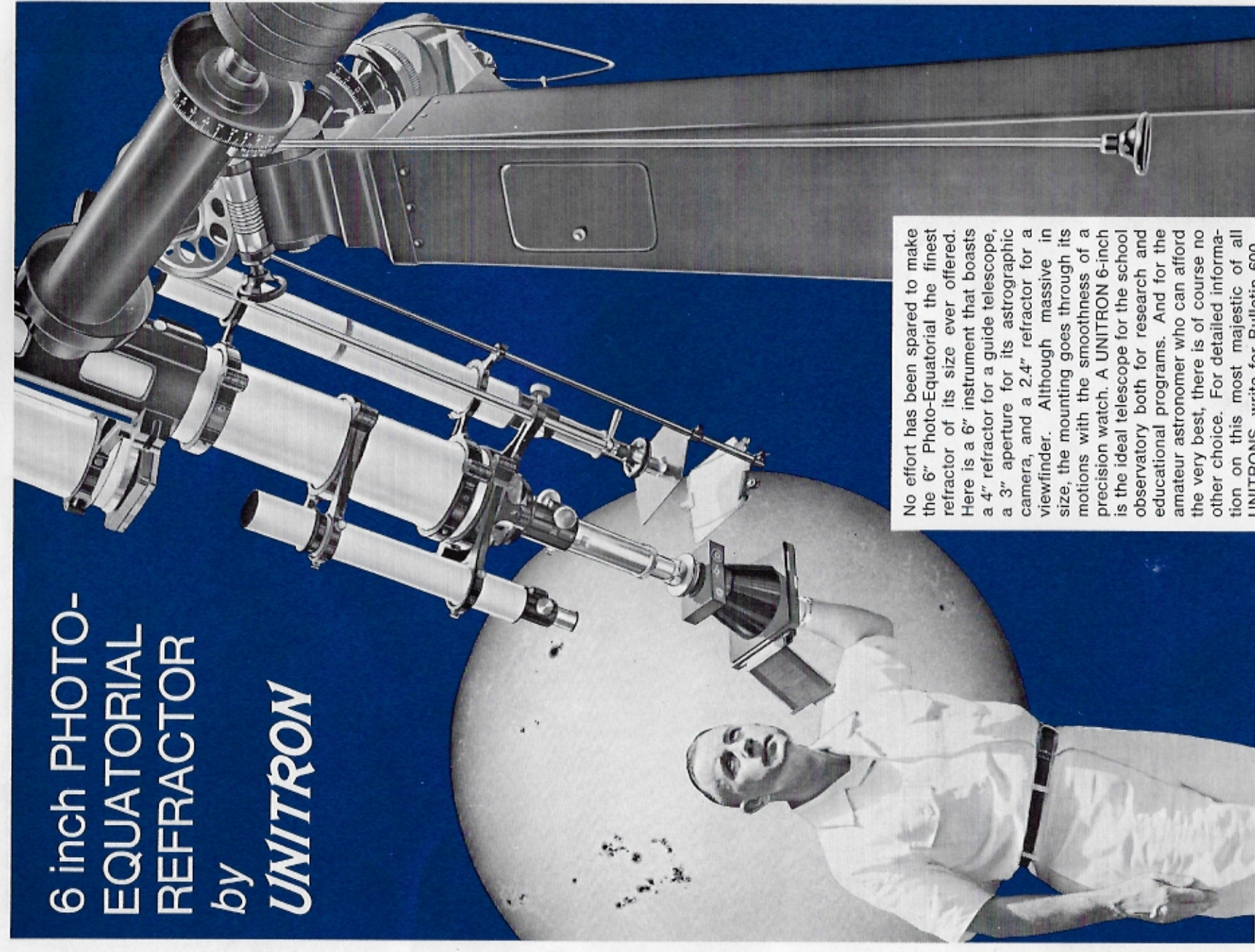

6 inch PHOTO-
EQUATORIAL
REFRACTOR
by **UNITRON**

No effort has been spared to make the 6" Photo-Equatorial the finest refractor of its size ever offered. Here is a 6" instrument that boasts a 4" refractor for a guide telescope, a 3" aperture for its astrographic camera, and a 2.4" refractor for a viewfinder. Although massive in size, the mounting goes through its motions with the smoothness of a precision watch. A UNITRON 6-inch is the ideal telescope for the school observatory both for research and educational programs. And for the amateur astronomer who can afford the very best, there is of course no other choice. For detailed information on this most majestic of all UNITRONS, write for Bulletin 600.

telescope accessories and components

by **UNITRON**

These accessories and components are all standard equipment on UNITRON Refractors and are therefore of the finest quality obtainable. Most items are illustrated on the refractors themselves and in such cases reference is made to the particular models.

VIEWFINDERS



From left to right: 23.5mm, 30mm, and 42mm viewfinders.

All models have coated, achromatic objectives and crossline eyepieces. Furnished with mounting brackets with centering screws for collimation as well as installation screws. The brackets are made of an aluminum alloy and are designed so that they may be mounted on tubes of any curvature and provide more than adequate support.

23.5mm, 6X (as shown on Model 128). Chromed brass tube.

30mm, 8X (as shown on Models 140, 142). Duralumin tube finished in white enamel.

EYEPIECES

Manufactured to exceptionally close tolerances to permit you to obtain the maximum performance of which your objective or mirror is capable. The following eyepieces with the exception of the 40mm have outside diameter 24.5mm (.97"). A plastic adapter bushing is available for 1 1/4" o.d. eyepiece holders at an additional cost. All eyepieces are coated.

40mm Monochro (1 1/4" o.d.)
40mm — as above, with crossline
25mm Ramsden

42mm, 10X (as shown on 4" Models). Air-spaced objective.

Duralumin tube finished in white enamel. Dewcap and dustcap.

62mm, 12.5X (as shown on 6" Models). 500mm (19.7") focal length, air-spaced objective. Furnished with 12.5X (40mm) Monochro eyepiece. Eyepieces of other focal lengths may be used. Prismatic star diagonal for 1 1/4" eyepieces. Duralumin tube finished in white. Chromed brass drawtube with Standard rack and pinion focusing. Dewcap and dustcap.

18mm Kellner
12.5mm Kellner
9mm Achromatized Symmetrical
9mm — as above, with crossline
7mm Achromatized Symmetrical
6mm Orthoscopic
5mm Orthoscopic
4mm Orthoscopic

60mm Kellner. This special eyepiece has 58mm o.d. and may be used only in the Super rack and pinion (or equivalent) or in a holder which will accept an eyepiece of this diameter. It is described and shown with Model 152.

VIEWFINDER MOUNTING BRACKETS

As used with UNITRON Guide Telescopes and Viewfinders. Centering screens for collimation. Brackets may be obtained already attached to UNICLAMPS of any larger diameter. For 1.6" tubes (23/16" i.d.), 2.4" tubes (3 1/8" i.d.), 4" tubes (5 5/16" i.d.)

OBJECTIVE LENSES

Achromatic, air-spaced, coated objectives mounted in a cell. These objectives are truly unique in the excellence of their definition. Superb optical corrections are obtained by exclusive lens designs and the use of the newest types of optical glass.

2.4" diameter, 3" diameter, and 4" diameter

Outer cell to attach to telescope tube is threaded to receive the objective lens cell. Dewcap and dustcap included.

For 2.4", 3", and 4" objectives

DUETRON Double Eyepiece Holder

Complete with clamping device.

Model A for UNITRONS (shown with Model 128)
Model B for 1 1/4" eyepiece holders

UNIHEX Eyepiece Selector

Complete with clamping device.

Model A for UNITRONS (shown on Model 114)
Model B for 1 1/4" eyepiece holders
Super-UNIHEX (shown with 5" Model)



telescope accessories and components

by **UNITRON**

SUN PROJECTING SCREENS



SUN PROJECTION SCREEN FOR 2.4" UNITRON WITH UNICLAMPS

As illustrated with Model 142. White metal screen with matching black metal shade, chromed brass extension rod with mounting brackets and screws.

Set for 2.4" Refractors (complete with UNICLAMPS)

Set for 3" Refractors with screens 6" x 6"

Set for 4" Refractors with screens 7" x 7"

ERECTING PRISM SYSTEM

As shown on Model 140. Accepts eyepieces of 24.5 mm o.d. Plastic bushing available to use in 1 1/4" eyepiece holders. To hold eyepiece of 1 1/4" o.d. the short adapter tube is needed in addition.

PRISMATIC STAR DIAGONALS

As shown on Model 140.

For 24.5mm o.d. eyepieces

For 1 1/4" o.d. eyepieces

SOLAR APERTURE DIAPHRAGMS

When observing or photographing the sun with 4" Refractors, and when photographing with the smaller models, an aperture diaphragm is recommended for reducing the heat and light intensity.

For 2.4" Refractors, single aperture

For 3" Refractors, single aperture

For 4" Refractors, single aperture (shown with Model 150)

For 4" Refractors, two apertures on revolving disk

SUNGLASS

For 24.5mm o.d. eyepieces (as shown with Model 150)

For 1 1/4" o.d. eyepieces

SUN DIAGONAL

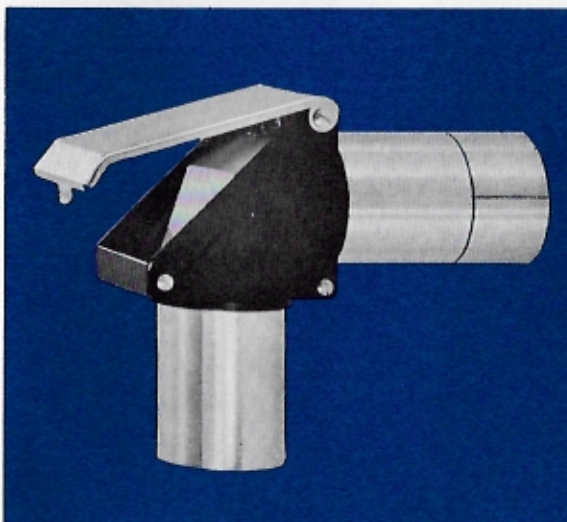

Herschel solar wedge. A right-angle viewing attachment for solar observation. Reduces the intensity of the sun for safe viewing with larger apertures.

Model A, for UNITRONS

Model B, for 1 1/4" eyepiece holders

RACK AND PINION FOCUSING MECHANISMS



Shown, left to right, are the Standard, Deluxe, and Super Models. The Deluxe and Super Models have locking devices for both the focusing sleeve and drawtube. Furnished complete with long drawtube and eyepiece holders for both 24.5mm o.d. and 1 1/4" o.d. eyepieces. The Super Model can, in addition, hold the 58mm o.d. 60mm f.l. eyepiece.

Standard Model (illustrated on Model 128)

Deluxe Model (illustrated on Model 145)

Super Model (illustrated on Model 152)

The couplings are 2 3/4" outside diameter. Additional charge for the above with coupling to fit 3 1/16" i.d. tubing. A heavy coupling to fit 4 3/8" o.d. is also available and aids in balancing the tube.

ADAPTER TUBES

Adapter to use 1 1/4" eyepieces and accessories in 24.5mm o.d. eyepiece holders. For use with the 40mm eyepiece in the standard 24.5mm star diagonal.

Extra long drawtube with reversible 24.5mm and 1 1/4" o.d. eyepiece holders.

telescope accessories and components

by **UNITRON**

ASTRO-CAMERAS



The UNITRON ASTRO-CAMERA 220, as illustrated above and with Model 145, is a light-weight camera designed especially for photography using the objective lens (or mirror) of the telescope as the principal optical element. A photo-ocular projects a magnified image at the film plane. The ocular can be removed to permit prime focus photography. An air operated curtain shutter of the Thornton-Pickard type gives speeds of 1/10 to 1/90 sec. in addition to bulb and time. Three double plateholders are included for 3 1/4"x4 1/4" glass plates. Cut film adapters, to convert plateholders for cut film, are available in sets of 6. The camera comes complete with groundglass focusing back, extension tubes, a special 30mm f.l. photo-ocular, filter, clamps, air-operated shutter release, cabinet and instructions.

Model 220A for UNITRONS

Model 220B for 1 1/4" o.d. eyepiece holders

COUNTERBALANCE CLAMPS

Consists of a heavy cylinder which clamps around the telescope tube to balance heavy accessories such as the Astro-Camera.

For 2.4" Models and 3" Models

REFRACTORS WITHOUT MOUNTINGS

The UNITRON 3", 4" 5" and 6" Refractors are available as separate units without the equatorial mountings, tripod or pier. Note carefully that the eyepieces, accessories, type of rack and pinion, and the equipment furnished is that of the equatorial (rather than altazimuth) models. For complete information refer to the catalog descriptions. These units may be purchased with some of the eyepieces and accessories omitted and in this case an allowance is given for omitted components equal to 90% of their prices.

Without mounting or tripod

3" Refractor, UNITRON Model 142,

4" Refractor, UNITRON Model 152,

5" Refractor, UNITRON Model 510,

6" Refractor, UNITRON Model 600,

Also see sections on Viewfinders and Guide Telescopes for 2.4" Refractors of focal length 500mm and 700mm, and the 4" Guide Telescope.

EQUATORIAL MOUNTING with TRIPOD or PIER

These mountings are sufficiently sturdy to accommodate larger refractors of average weight and much larger reflectors.

As supplied with UNITRON 2.4" Model 128, with tripod and cabinet

As supplied with UNITRON 3" Model 142, with tripod and cabinet

As supplied with UNITRON 4" Model 152, with tripod and cabinet

As supplied with UNITRON 4" Model 166, with metal pier

As supplied with UNITRON 5" Model 510, with tripod

As supplied with UNITRON 5" Model 530, with metal pier

As supplied with UNITRON 6" Model 600, with metal pier

SYNCHRONOUS MOTOR CLOCK DRIVES

Synchronous Motor Drive for 110-120 volts, 60 cycles, complete with coupling and hardware to attach to worm gear shaft.

For 2.4", 3" and 4" Models

UNICLAMPS

For attaching accessories to the telescope tube without drilling holes in the tube. Attach or remove in a jiffy.

For 2.4" Models (2 11/16" i.d.)

For 3" Models (3 1/4" i.d.)

For 4" Models (4 1/4" i.d.)

UNICLAMP CAMERA BRACKET



A convenient device to attach a camera to your telescope as illustrated with Model 145.

For 2.4", 3" and 4" Models

UNIBALANCE TUBE ASSEMBLY

For 3" Models with UNICLAMPS (as shown with Model 145)

For 4" Models with UNICLAMPS (as shown with Models 160, 166)

PHOTOGRAPHIC GUIDE TELESCOPES

Coated, air-spaced, achromatic objective. Duralumin tube finished in white with dewcap and dustcap. Rack and pinion focusing mechanism with chromed drawtube. Prismatic star diagonal and 9mm Achromatized Symmetrical crossline eyepiece. (Eyepieces of other focal lengths may also be used.) Furnished with mounting brackets and centering screws for collimation (but without UNICLAMPS).

2.4" Model, 78X, as supplied with UNITRON 3" and 4" Photographic Equatorials.

4" Model, 167X, as supplied with UNITRON 6" Photographic Equatorials. With wooden cabinet.

